

1

2

3

4

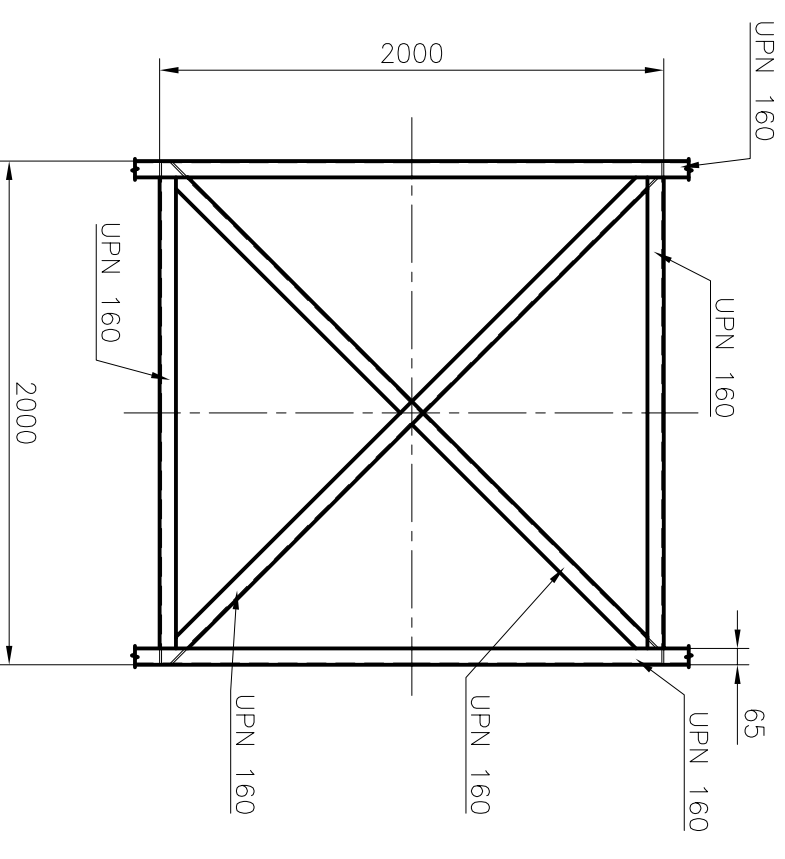
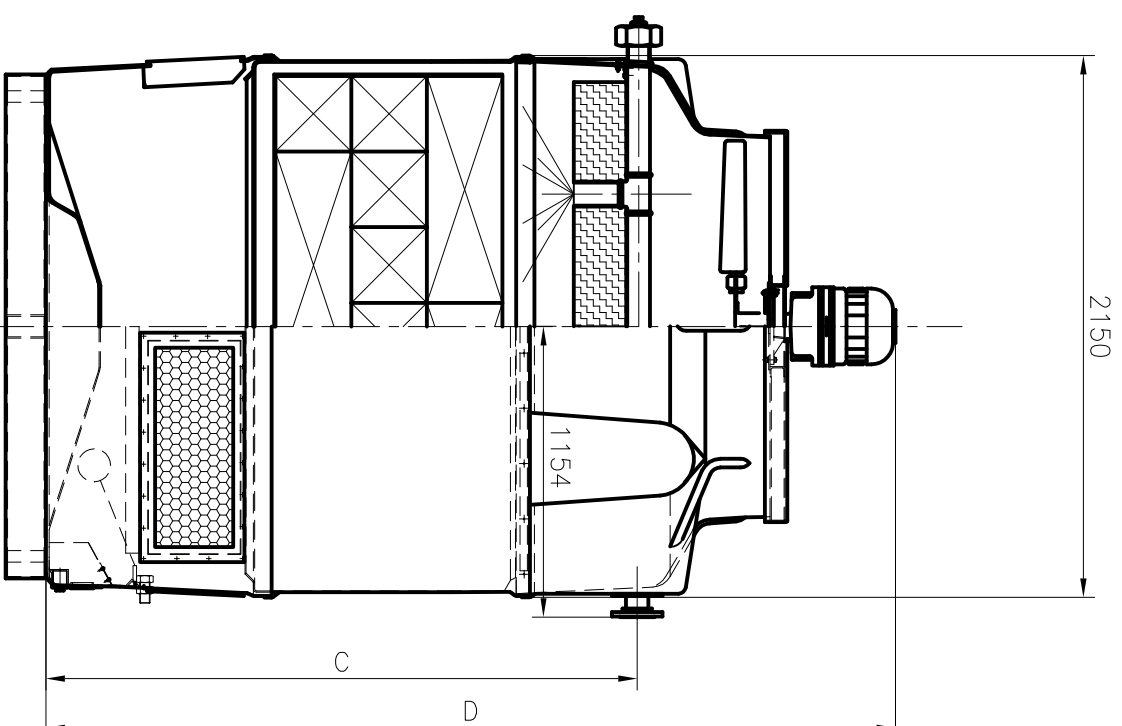
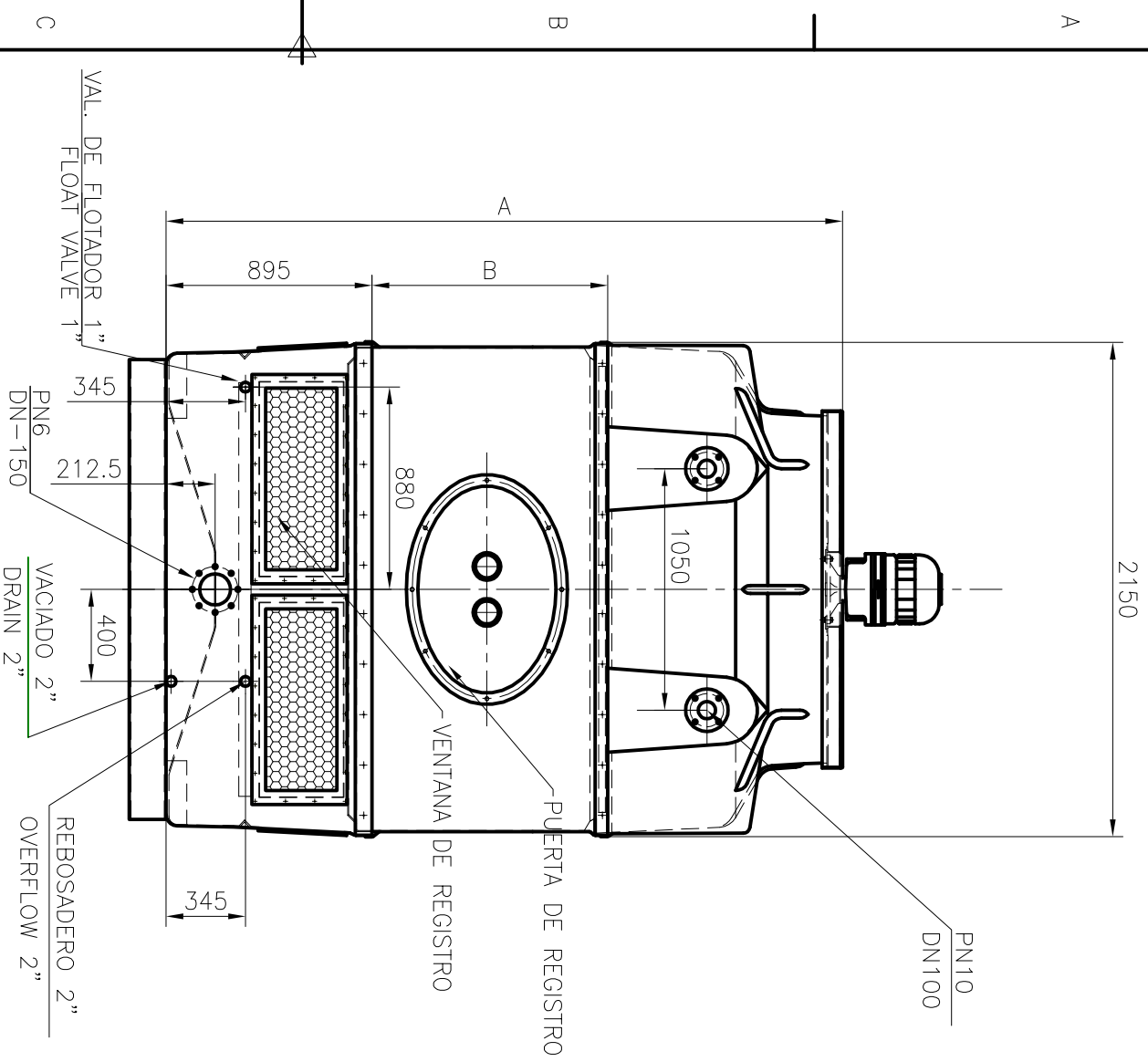

BANCADA A TÍTULO INFORMATIVO
STRUCTURE FOR INFORMATION

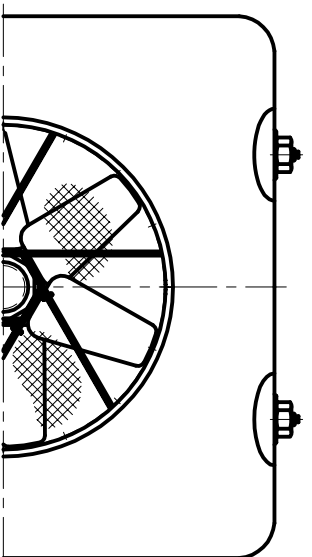

TORRE TOWER	A (mm)	B (mm)	C (mm)	D (mm)	Peso en vacío Net Weight (Kg)	Peso servicio (Kg) Operating weight
EWK 441/06	2705	790	2110	3135	725	2745
EWK 441/09	2940	1025	2345	3370	730	2890
EWK 441/12	3265	1350	2670	3695	800	3005
EWK 441/15	3495	1580	2900	3925	845	3185

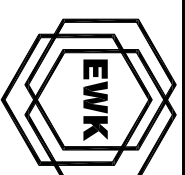

ESCALA
1:30
U.DIM. mm



EWK 441

Ref. 441-A/408